

CHAPTER 37

WOOD ULTIMATE INSERT DOUBLE HUNG

Product Information

Product Specifications	37.2
Egress/NFRC	37.5
Measurement Conversions	37.6

Elevations and Sections

Section Details: Operator	37.9
Section Details: Transom	37.11
Section Details: Picture	37.13
Section Detail: Mullions	37.15
Divided Lite Options	37.16
Rectangular Daylight Opening Calculations	37.17
Trim Kit Details	37.18

NOTE:

Specifications and technical data are subject to change without notice.

Allow 1/16" (2) tolerance on all measurements.

Metric measurements are shown in parenthesis.

For accessories dimensions and applications see the Accessories section of this manual.

For technical assistance about Marvin products you may call our Architectural Hotline 1-800-346-3363 or visit our website: www.Marvin.com.

WOOD ULTIMATE INSERT DOUBLE HUNG

PRODUCT SPECIFICATION

SECTION 08 52 00

WOOD ULTIMATE INSERT DOUBLE HUNG WINDOW

PART 1 GENERAL

1.1 SECTION INCLUDES

- A. Wood ultimate insert [double hung] [single hung] and related [picture] [transom] window complete with hardware, glazing, weather-strip, [insect screen] [removable grille] [simulated divided lite] [authentic divided lite] [grilles-between-the-glass] and standard or specified anchors, trim and attachments.

1.2 RELATED SECTIONS

- A. Section 01 33 23-Submittal Procedures: Shop Drawings, Product Data, and Samples
- B. Section 01 62 00-Product Options
- C. Section 01 65 00-Product Delivery
- D. Section 01 66 00-Storage and Handling Requirements
- E. Section 01 71 00-Examination and Preparation
- F. Section 01 73 00-Execution
- G. Section 01 74 00-Cleaning and Waste Management
- H. Section 01 76 00-Protecting Installed Construction
- I. Section 06 22 00-Millwork: Wood trim other than furnished by window manufacturer
- J. Section 07 92 00-Joint Sealants: Sill sealant and perimeter caulking
- K. Section 09 90 00-Paints and Coatings: Paint or stain other than factory applied finish

1.3 REFERENCES

- A. American Society for Testing and Materials (ASTM):
 - 1. E 283: Standard Test Method for Rate of Air Leakage Through Exterior Windows, Curtain Walls, and Doors.
 - 2. E 330: Standard Test Method for Structural Performance of Exterior Windows, Curtains Walls, and Doors by Uniform Static Air Pressure Difference.
 - 3. E 547: Standard Test Method for Water Penetration of Exterior Windows, Curtain Walls, and Doors by Cyclic Static Air Pressure Differential.
 - 4. E 774: Specification for Sealed Insulated Glass Units.
 - 5. C 1036: Standard Specification for Flat Glass.
- B. American National Standards Institute / National Wood Window and Door Association NWDA: I.S.4: Industry Standard for Water Repellent Preservative Treatment for Millwork.
- C. American Architectural Manufacturers Association / Window and Door Manufacturers Association (AAMA / WDMA): ANSI / AAMA / NWWDA 101 / I.S.2-97 Voluntary Specifications for Aluminum, Vinyl (PVC) and Wood Windows and Glass Doors and 101 / I.S.2 / NAFS-02 Voluntary Performance Specification for Windows, Skylights and Glass Doors.
- D. Window and Door Manufacturers Association (WMDA): 101 / I.S.2 WDMA Hallmark Certification Program.
- E. Sealed Insulating Glass Manufacturers Association / Insulating Glass Certification Council (SIGMA / IGCC).
- F. American Architectural Manufacturers Association (AAMA): AAMA 2605 Voluntary Specification for High Performance Organic Coatings on Architectural Extrusions and Panels.
- G. National Fenestration Rating Council (NFRC): 100: Procedure for Determining Fenestration Product Thermal Properties.

1.4 SYSTEM DESCRIPTION

- A. Design and Performance Requirements:
 - 1. Window Units shall be designed to comply with ANSI / AAMA / WDMA I.S.2-97 and 101 / I.S.2 / NAFS-02.
 - a. Double Hung: H-LC30 up to 44 X 77.608 Inside Opening.
 - b. Transom: TR-LC30 up to 44 X 23.051 Inside Opening.
 - c. Picture: F-LC30 up to 68 X 77.608 Inside Opening.
 - 2. Air leakage shall not exceed the following when tested at 1.57 psf according to ASTM E 283: 0.30 cfm per square foot of frame.
 - 3. No water penetration shall occur when units are tested at the following pressure according to ASTM E 547: H-LC-30, TR-LC-30, and F-LC30 - 4.5 psf.
 - 4. Window assembly shall withstand the following positive or negative uniform static air pressure difference without damage when tested according to ASTM E 330: H-LC30, TR-LC-30 and F-LC30 - 45 psf.

1.5 SUBMITTALS

- A. Shop Drawings: Submit shop drawings under provisions of Section 01 33 23.
- B. Product Data: Submit catalog data under provisions of Section 01 33 23.
- C. Samples:
 - 1. Submit corner section under provisions of Section 01 33 23.
 - 2. Include glazing system, quality of construction, and specified finish.
- D. Quality Control Submittals: Submit manufacture's certifications indicating compliance with specified performance and design requirements under provisions of Section 01 33 23.

WOOD ULTIMATE INSERT DOUBLE HUNG

PRODUCT SPECIFICATION

1.6 QUALITY ASSURANCE

- A. Regulatory Requirements: Emergency Egress or Rescue: Comply with requirements for sleeping units of [IBC International Building Code] [BOCA Basic Building Code] [Southern Building Code] [Uniform Building Code] [_____].

1.7 DELIVERY

- A. Comply with provisions of Section 01 65 00.
B. Deliver in original packaging and protect from weather.

1.8 STORAGE AND HANDLING

- A. Prime or seal wood surfaces, including surface to be concealed by wall construction, if more than thirty (30) days will expire between delivery and installation.
B. Store window units in an upright position in a clean and dry storage area above ground and protect from weather under provisions of Section 01 66 00.

1.9 WARRANTY

- A. Windows shall be warranted to be free from defects in manufacturing, materials, and workmanship for a period of ten (10) years from purchase date.
B. Insulating glass shall be warranted against visible obstruction thru the glass caused by a failure of the insulating glass air seal for a period of twenty (20) years from the date of original purchase.

PART 2 PRODUCTS

2.1 MANUFACTURED UNITS

- A. Description: Wood Ultimate Insert [Double Hung] [Single Hung] [Stationary] units as manufactured by Marvin Windows and Doors, Warroad, Minnesota.

2.2 ALUMINUM CLAD WOOD ULTIMATE INSERT DOUBLE HUNG MATERIALS

- A. Frame: Finger jointed edge-glued pine head and side jambs with clear pine interior veneer [finger jointed edge glued mahogany head and side jambs with clear mahogany interior veneer] [finger jointed edge glued vertical grain Douglas fir head and side jambs with clear vertical grain Douglas fir interior veneer]. Finger jointed [clear] sill, kiln dried to a moisture content no greater than twelve (12) percent at the time of fabrication. Water repellent preservative treated in accordance with WDMA I.S.4. Frame thickness: 11/16 inch (17 mm) head and side jambs, 1 inch (26 mm) sill, 8 degree bevel, 1-7/16 inches (37 mm) flat sill available. Frame width: 4-9/16 inches (116 mm).
- B. Sash: Clear pine [mahogany] [vertical grain Douglas fir] kiln dried to a moisture content no greater than twelve (12) percent at the time of fabrication. Water repellent preservative treated in accordance with WDMA I.S.4. Sash thickness: 1-5/8 inches (41 mm) for double hung, 1-5/8 inches (41 mm) or 2 inches (51 mm) for picture units. Removable exterior glazing stops. Corners slot and tenoned. Operable sash tilt to interior for cleaning or removal.
- C. Glazing: Select quality complying with ASTM C 1036. Insulating glass SIGMA/IGCC certified to performance level CBA when tested in accordance with ASTM E 774.
1. Glazing method:
[Insulating glass] [Altitude adjusted] [single glass]
 2. Glass type:
[Clear]
[Bronze]
[Gray]
[Reflective bronze]
[Low E II] [Argon gas]
[Tempered]
[Obscure]
[Laminated]
 3. Glazing seal: Silicone bedding, exterior and interior.
- D. Finish:
1. Interior / Exterior: [Treated bare wood] [Latex prime coat, white - available for pine wood species only].
- E. Hardware:
1. Balance system: Coil spring block and tackle with nylon cord and fiber filled nylon clutch.
 2. Jamb track: Vinyl extrusion. Color: [Beige] [White].
 3. Lock: High pressure zinc die-cast [solid brass] cam lock and keeper. Finish: Phosphate coated and electrostatically painted Satin Taupe [Bronze] [White] [Brass] [Satin Chrome] [Satin Nickel] [Antique Brass] [Oil rubbed Bronze].
- F. Weather-strip: Unit is weather-stripped at jambs with a foam type material for added long-term performance to seal against both the bottom sash and top sash stiles. The bottom sash has a weather-strip to seal against the sill, the top check rail has a weather-strip to seal against the bottom check rail, and the top rail seals against a weather-strip on the head-jamb parting stop. Stationary units: Continuous, bulb weather-strip at perimeter of sash, concealed slotted bulb weather-strip on exterior of sash, pile weather-strip on interior of blind stop, dual durometer bulb weather-strip at bottom rail. Color: Beige.

WOOD ULTIMATE INSERT DOUBLE HUNG

PRODUCT SPECIFICATION

- G. Insect Screens: Field installed [half screen] [full screen]. Half screen covers bottom sash opening. Screen cloth, 18 X 16 mesh: Charcoal fiberglass [Charcoal aluminum wire] [Black aluminum wire] [Bright aluminum wire] [Bright bronze wire]. Aluminum frame finish: Fluoropolymer modified acrylic topcoat applied over primer. Meets or exceeds AAMA 2605 requirements. Standard color: [Stone White] [Bronze] [Bahama Brown] [Pebble Gray] [Evergreen]. [Select color: [Ebony] [Arctic White] [Sierra White] [French Vanilla] [Desert Beige] [Wineberry] [Coconut Cream] [Cashmere] [Cadet Gray] [Cumulus Gray] [Sherwood Green] [Hampton Sage] [Cascade Blue] [Cobalt Blue]]. [Custom color - contact your Marvin representative].
- H. Removable Grilles: [3/4 X 15/32 inch (19 mm X 12 mm)] [1-1/8 X 15/32 inch (29 mm by 12 mm)] Pine only.
 - 1. Pattern: [Rectangular] [Custom lite layout].
 - 2. Finish: Match interior sash finish.
- I. Authentic Divided Lites (ADL): [7/8 inch (22 mm) single glaze pine [mahogany] [vertical grain Douglas fir] muntin] [1-11/16 inches (43 mm) insulating glass pine [mahogany] [vertical grain Douglas fir] muntin].
 - 1. Pattern: [Rectangular] [Custom lite layout].
 - 2. Finish: Match sash finish.
- J. Simulated Divided Lites (SDL): [7/8 inch (22 mm) wide] [1 1/8 inch (29 mm) wide] [with internal spacer bars] pine [mahogany] [vertical grain Douglas fir] adhered to glass with double coated acrylic foam tape.
 - 1. Pattern: [Rectangular] [Custom lite layout].
 - 2. Finish: Match sash finish.
- K. Grilles-between-the-glass (GBG): 11/16 inch (17 mm) white contoured aluminum bar. Optional flat aluminum spacer bar, contact your Marvin representative.

2.3 ACCESSORIES AND TRIM

- A. Installation Accessories:
 - 1. Package of installation hardware consisting of:
 - a. Two 5/16 inch - #10 x 2 1/2 inch jamb jack screws
 - b. Four #7 x 2 inch Phillips pan head installation screws
 - c. Two jamb liner check rail pads
 - d. Four wood flat head plugs (interior)
 - e. Screen grommet(s)
 - 2. Sash lifts: High pressure zinc die-cast. Color: Satin Taupe [Bronze] [White] [Brass] [Satin Chrome] [Satin Nickel] [Antique Brass] [Oil Rubbed Bronze].
 - 3. Exterior trim

PART 3 EXECUTION

3.1 EXAMINATION

- A. Verification of Conditions: Before installation, verify openings are plumb, square, and of proper dimension as required in Section 01 71 00. Report frame defects or unsuitable conditions to the General Contractor before proceeding.
- B. Acceptance of Conditions: Beginning of installation confirms acceptance of existing conditions.

3.2 INSTALLATION

- A. Comply with Section 01 73 00.
- B. Assemble and install window unit according to manufacture's instructions and reviewed shop drawings.
- C. Install sealant and related backing materials at perimeter of unit or assembly in accordance with Section 07 92 00 Joint Sealants. Do not use expansive foam sealant.
- D. Install accessory items as required.

3.3 CLEANING

- A. Remove visible labels and adhesive residue from glass according to manufacture's instructions.
- B. Leave windows and glass in a clean condition. Final cleaning as required in Section 01 74 00.

3.4 PROTECTING INSTALLED CONSTRUCTION

- A. Comply with Section 01 76 00.
- B. Protect windows from damage by chemicals, solvents, paint, or other construction operations that may cause damage.

WOOD ULTIMATE INSERT DOUBLE HUNG

EGRESS / NFRC VALUES

MINIMUM EGRESS REQUIREMENTS	
Inside Opening Width	Inside Opening Height
26	84 1/16
28	78
30	72 15/16
32	68 9/16
34	64 3/4
36	61 7/16
38 or greater	58 7/16 or greater

International Building Code - 2000

Section 1009 Emergency Escape and Rescue

1009.2 Minimum size: Emergency escape and rescue openings shall have a minimum net clear opening of 5.7 square feet (0.53m²). Exception: The minimum net clear opening for emergency escape and rescue openings on the ground level at grade is 5.0 square feet (0.46m²).

1009.2.1 Minimum dimensions: The minimum net clear opening height dimension shall be 24 inches (610 mm). The net clear opening width dimension shall be 20 inches (508 mm). The net clear opening dimensions shall be the result of normal operation of the opening.

1009.3 Maximum height from the floor: Emergency escape and rescue opening shall have the bottom of the clear opening not greater than 44 inches (1118 mm) measured from the floor.

1009.4 Operational constraints: Emergency escape and rescue openings shall be operational from the inside of the room without the use of keys or tools. Bars, grilles, grates, or similar devices are permitted to be placed over emergency escape and rescue openings provided the minimum net clear opening size complies with Section 1009.2 and such devices shall be releasable or removable from the inside without the use of a key, tool, or force greater than that which is required for normal operation of the escape and rescue opening.

Code restrictions may vary depending on your local building codes.

Note: Refer to page 2.1 for inside opening illustration.

WINDH EGRESS GUIDELINES

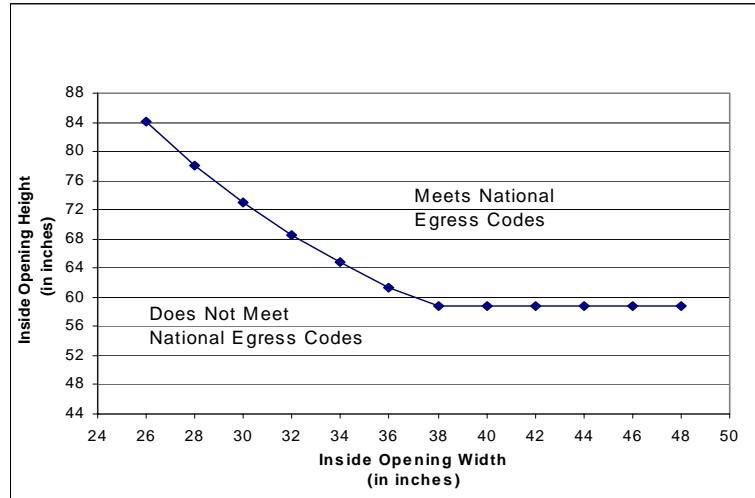

* When installed in accordance to recommended measuring and installation guidelines, these sizes meet national egress codes for fire evacuation. Local codes may differ.

WINDH EGRESS MEASUREMENTS

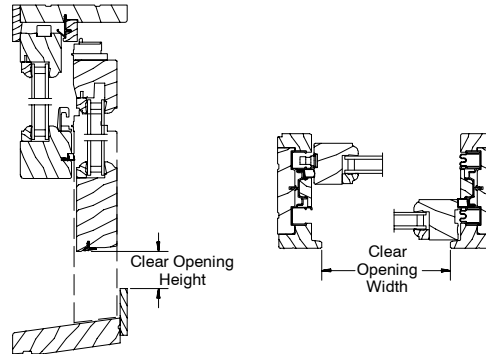

CERTIFIED NFRC UNIT VALUES

WOOD ULTIMATE INSERT DOUBLE HUNG	U-FACTOR	R-VALUE	SHGC	VLТ	ENERGY STAR
WOOD ULTIMATE INSERT DOUBLE HUNG / SINGLE HUNG					
Size Tested	47 x 59	47 x 59	47 x 59	47 x 59	
Insulating glass	0.46	2.17	0.55	0.58	-
Insulating glass - SDL	0.46	2.17	0.49	0.51	-
Insulating glass - SDL with spacer bars	0.46	2.17	0.49	0.51	-
Insulating Low E II glass	0.33	3.03	0.30	0.51	N, NC, SC, S
Insulating Low E II glass - SDL	0.33	3.03	0.27	0.45	N, NC, SC, S
Insulating Low E II glass - SDL with spacer bars	0.34	2.94	0.27	0.45	N, NC, SC, S
Insulating Low E II glass - Argon	0.30	3.33	0.29	0.51	N, NC, SC, S
Insulating Low E II glass - Argon, SDL	0.30	3.33	0.26	0.45	N, NC, SC, S
Insulating Low E II glass - Argon, SDL with spacer bars	0.31	3.23	0.26	0.45	N, NC, SC, S

Product Values are determined using the National Fenestration Rating Council Procedures for determining fenestration product values.

U-Value: (Btu/hr-sq. ft-°F) Lower the U-value, the greater the resistance to heat flow and better its insulating value.

R-Value: (1/U-Value) Higher the R-Value, the greater the resistance to heat flow and better its insulating value.

VLТ: Visible Light Transmittance - Percentage of visible light transmitted through the unit.

SHGC: Solar Heat Gain Coefficient: The lower a window's SHGC, the less solar heat it transmits, and the greater its shading ability.

NOTE: Capillary tubes are required for IG units at high elevations. Argon will not be furnished in units with capillary tubes. Contact the Architectural Department Hotline at (800-346-3363) for additional NFRC Values.

WOOD ULTIMATE INSERT DOUBLE HUNG

OPERATOR GUIDELINES / WINDH MEASUREMENT CONVERSIONS

Glazing Type	Operator Size Guidelines				Glass Size Maximum Square Feet per Sash
	Inside Opening Width		Inside Opening Height		
	Minimum	Maximum	Minimum	Maximum	
Insulating Glass	13 3/4" (349)	48" (1219)	23 21/32" (601)	85 19/32" (2174)	10 sq. feet (.93) sq. meters

Note: Units with 3/16" tinted glass have a 9 (.84) sq. ft. maximum glass size per sash.

Note: Some restrictions may apply. Contact your Marvin representative.

WINDH Measurement Conversions		
		<i>Not affected by sill type</i>
From Daylight Opening to:	Width	Height
Bottom Sash OM	+3 17/32" (90)	+5 11/16" (144)
Top Sash OM	+3 17/32" (90)	+3 7/8" (98)
Glass OM	+1 1/16" (27)	+1 1/16" (27)
Screen OM	+4 31/32" (126)	DLO + DLO +9 9/32" (236)
Grille	order by DLO	order by DLO

WINDH Measurement Conversions			
From Inside Opening to:	Width	*Height Flat Bottom Frame	*Height 8 Degree Frame Bevel
Bottom Sash OM	-3 9/32" (83)	-10 9/32" (261) ÷ 2 + 5 11/16" (144)	-9 27/32" (250) ÷ 2 + 5 11/16" (144)
Top Sash OM	-3 9/32" (83)	-10 9/32" (261) ÷ 2 + 3 7/8" (98)	-9 27/32" (250) ÷ 2 + 3 7/8" (98)
Daylight Opening	-6 13/16" (173)	-10 9/32" (261) ÷ 2	-9 13/16" (249) ÷ 2
Glass OM	-5 3/4" (146)	-8 5/32" (207) ÷ 2	-7 23/32" (196) ÷ 2
Screen OM	-1 27/32" (47)	-1" (25)	-9/16" (14)
Frame OM @ Interior	-3/8" (10)	-1/4" (6)	-1/4" (6)
Frame OM @ Exterior	-3/8" (10)	-1/4" (6)	+3/16" (5)

* If the existing sill is less than 8 degrees the replacement unit will be manufactured with a flat bottom. If the angle of the existing sill is 8 degrees or greater the unit will be made with an 8 degree frame bevel.

WOOD ULTIMATE INSERT DOUBLE HUNG

TRANSOM GUIDELINES / WINDT MEASUREMENT CONVERSIONS

Glazing Type	Transom Size Guidelines				Glass Size Maximum Square Feet
	Inside Opening Width		Inside Opening Height		
	Minimum	Maximum	Minimum	Maximum	
Insulating Glass	13 3/4" (349)	48" (1219)	13 1/8" (333)	23" (584)	5 sq. feet (.46) sq. meters

Note: Some restrictions may apply. Contact your Marvin Representative.

WINDT Measurement Conversions		
From Daylight Opening to:	Width	Height
Sash OM	+3 17/32" (90)	+4 11/32" (110)
Glass OM	+1 1/16" (27)	+1 1/16" (27)
Grille	order by DLO	order by DLO

WINDT Measurement Conversions			
From Inside Opening to:	Width	*Height Flat Bottom Frame	*Height 8 Degree Frame Bevel
Sash OM	-3 9/32" (83)	-2 11/32" (60)	-1 29/32" (48)
Daylight Opening	-6 13/16" (173)	-6 11/16" (170)	-6 1/4" (159)
Glass OM	-5 3/4" (146)	-5 5/8" (143)	-5 3/16" (132)
Frame OM @ Interior	-3/8" (10)	-1/4" (6)	-1/4" (6)
Frame OM @ Exterior	-3/8" (10)	-1/4" (6)	+3/16" (5)

* If the existing sill is less than 8 degrees the replacement unit will be manufactured with a flat bottom. If the angle of the existing sill is 8 degrees or greater the unit will be made with an 8 degree frame bevel.

WOOD ULTIMATE INSERT DOUBLE HUNG

PICTURE GUIDELINES / WINDP MEASUREMENT CONVERSIONS

Glazing Type	Picture Size Guidelines				Glass Size Maximum Square Feet
	Inside Opening Width		Inside Opening Height		
	Minimum	Maximum	Minimum	Maximum	
Insulating Glass 1" (25)	13 5/8" (346)	68" (1727)	14 7/32" (361)	85 19/32" (2174)	34 sq. feet (3.16) sq. meters

Note: Some restrictions may apply. Contact your Marvin Representative.

WINDP Measurement Conversions		
		<i>Not affected by sill type</i>
From Daylight Opening to:	Width	Height
Sash OM	+4 7/8" (124)	+5 21/32" (144)
Glass OM	+1 3/16" (30)	+1 3/16" (30)
Grille	order by DLO	order by DLO

WINDP Measurement Conversions			
From Inside Opening to:	Width	*Height Flat Bottom Frame	*Height 8 Degree Frame Bevel
Sash OM	-1 15/16" (49)	-2 1/4" (57)	-1 13/16" (46)
Daylight Opening	-6 13/16" (173)	-7 29/32" (201)	-7 15/32" (190)
Glass OM	-5 5/8" (143)	-6 23/32" (172)	-6 9/32" (159)
Frame OM @ Interior	-3/8" (10)	-1/4" (6)	-1/4" (6)
Frame OM @ Exterior	-3/8" (10)	-1/4" (6)	+3/16" (5)

* If the existing sill is less than 8 degrees the replacement unit will be manufactured with a flat bottom. If the angle of the existing sill is 8 degrees or greater the unit will be made with an 8 degree frame bevel.

WOOD ULTIMATE INSERT DOUBLE HUNG

SECTION DETAILS: OPERATOR

SCALE: 3" = 1' 0"

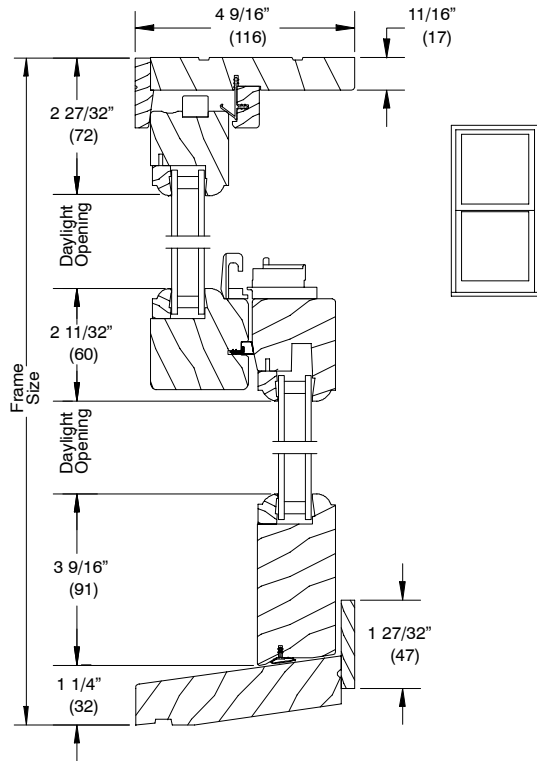

Head Jamb, Checkrail,
with Beveled Frame

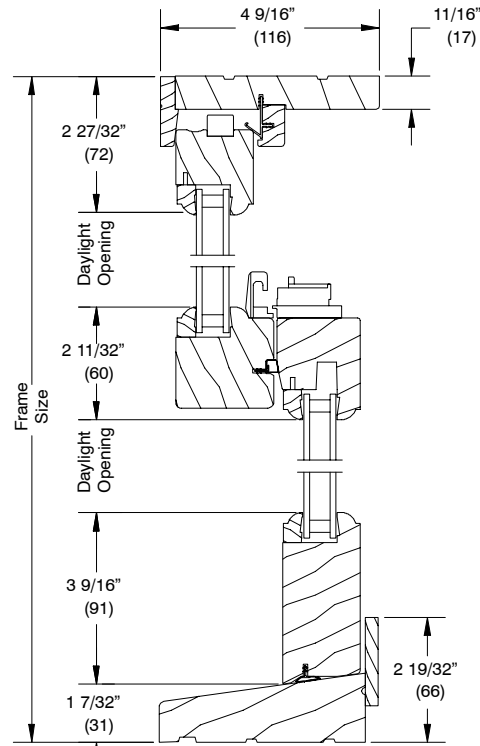

Head Jamb, Checkrail,
with Flat Frame

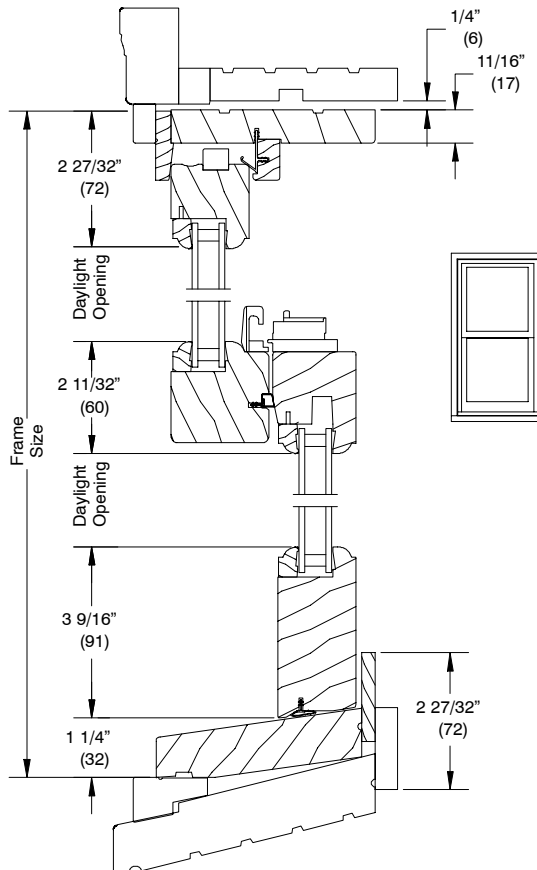

Head Jamb, Checkrail, with Beveled Frame
installed in existing frame

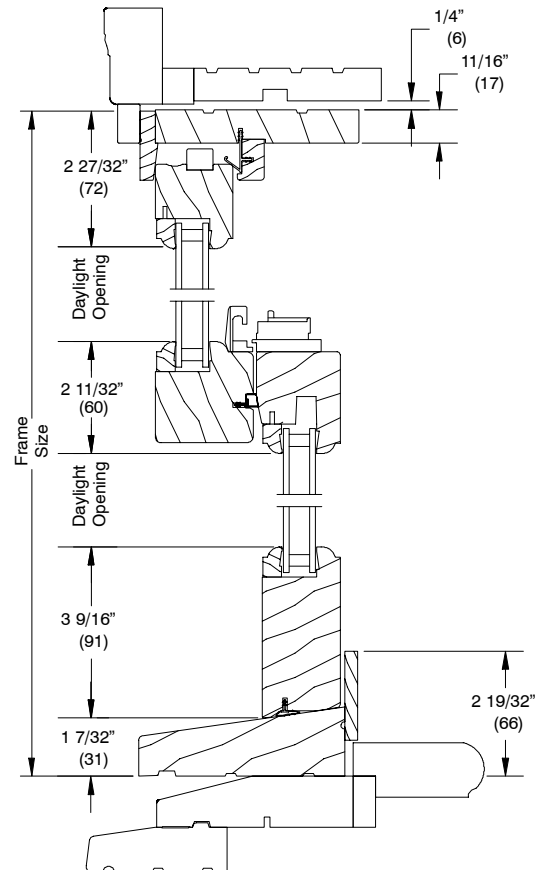

Head Jamb, Checkrail, with Flat Frame
installed in existing frame

WOOD ULTIMATE INSERT DOUBLE HUNG

SECTION DETAILS: OPERATOR

SCALE: 3" = 1' 0"

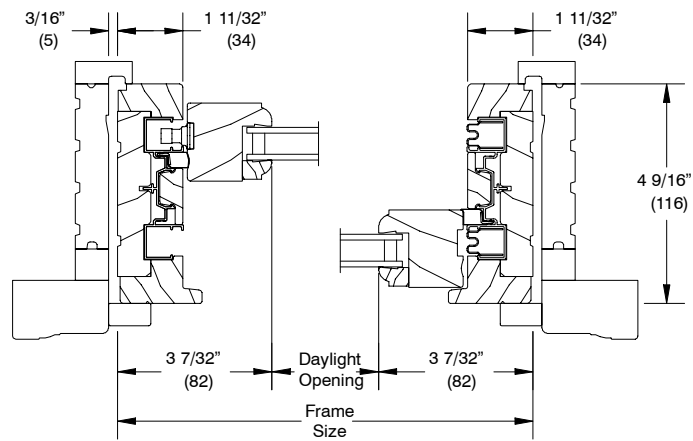
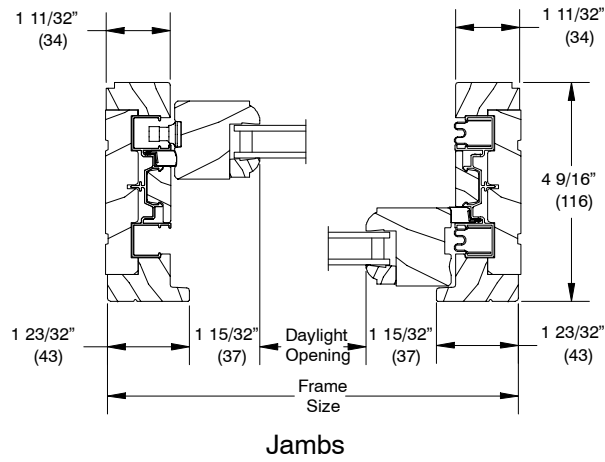

WOOD ULTIMATE INSERT DOUBLE HUNG

SECTION DETAILS: TRANSOM

SCALE: 3" = 1' 0"

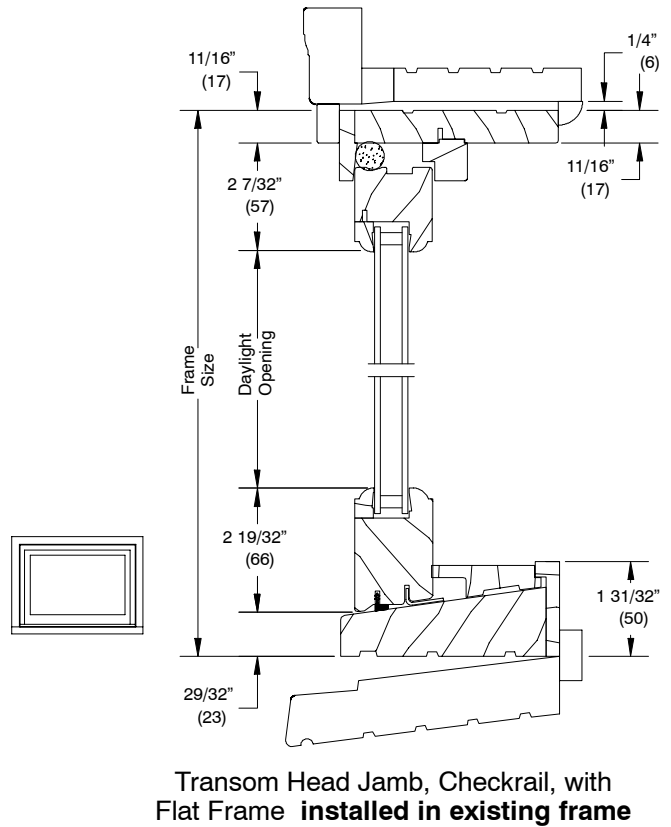
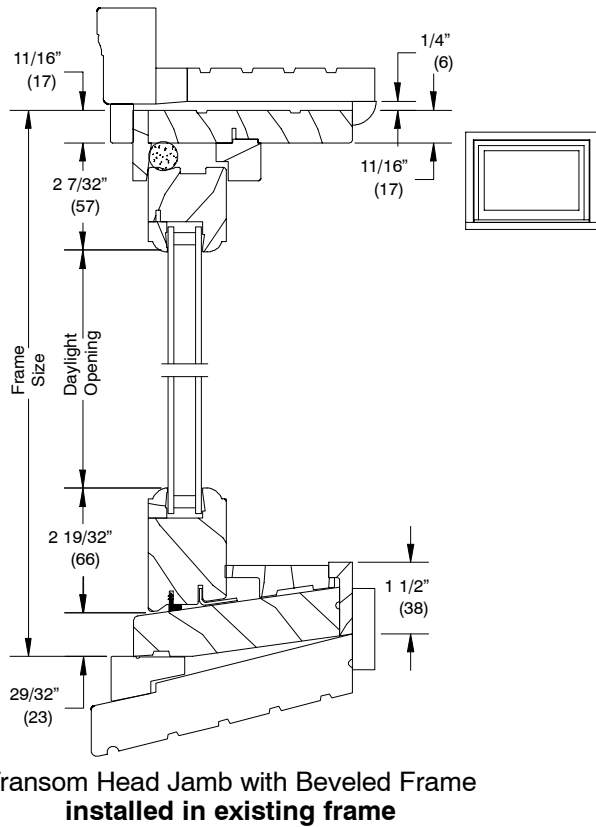
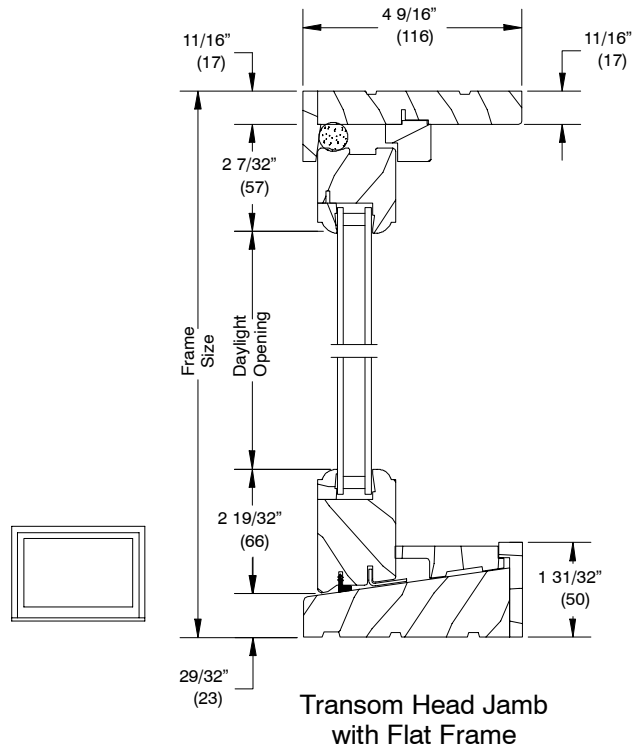
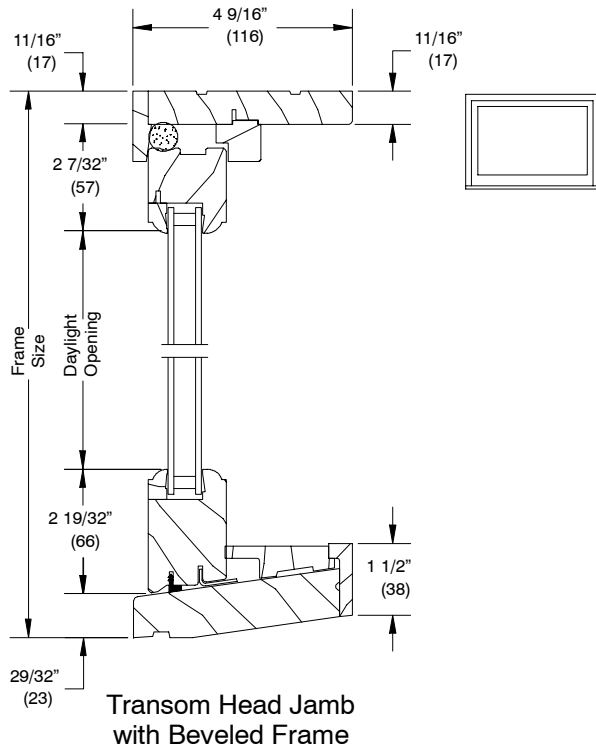

WOOD ULTIMATE INSERT DOUBLE HUNG

SECTION DETAILS: TRANSOM

SCALE: 3" = 1' 0"

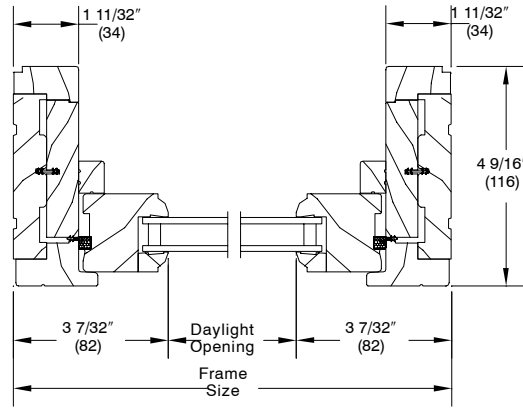

Transom Jamb

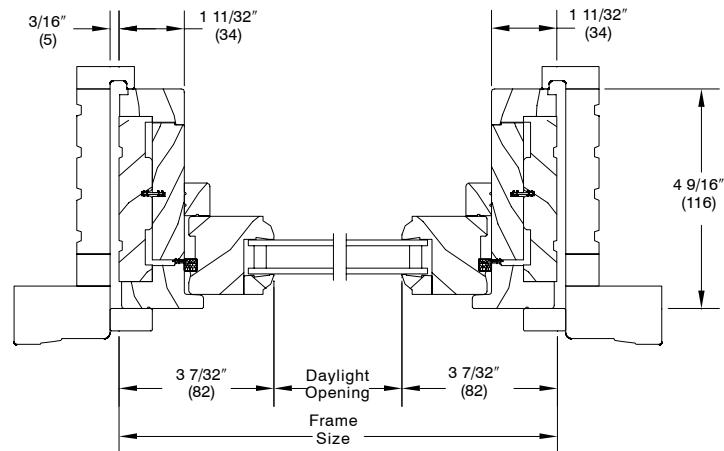

Transom Jamb installed in existing frame

WOOD ULTIMATE INSERT DOUBLE HUNG

SECTION DETAILS: PICTURE

SCALE: 3" = 1' 0"

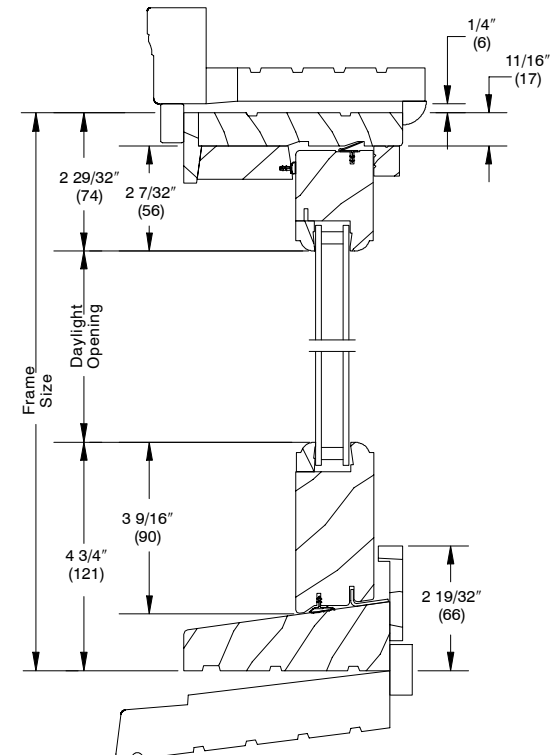
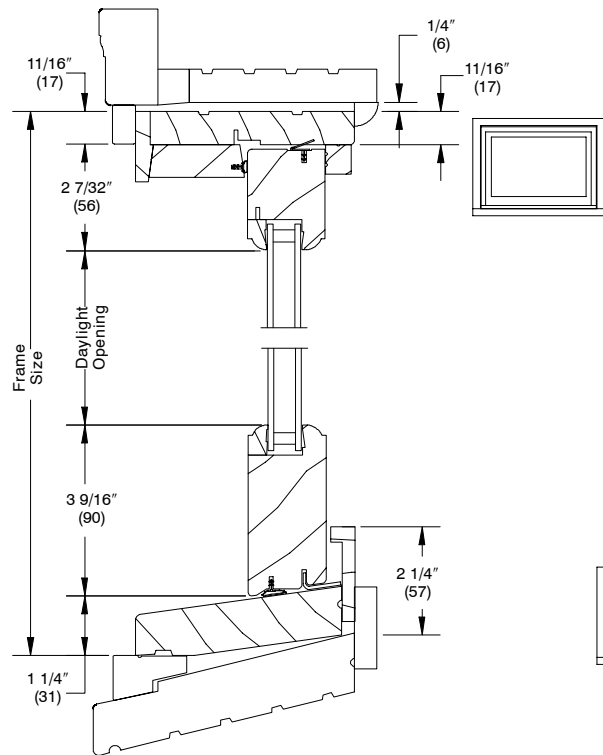
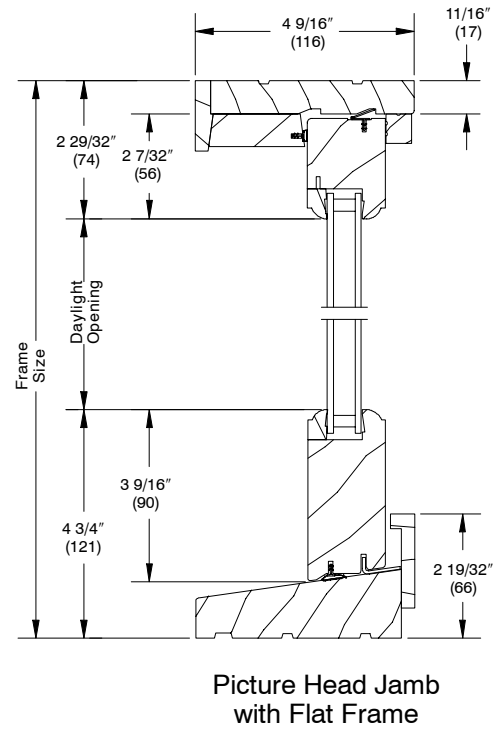
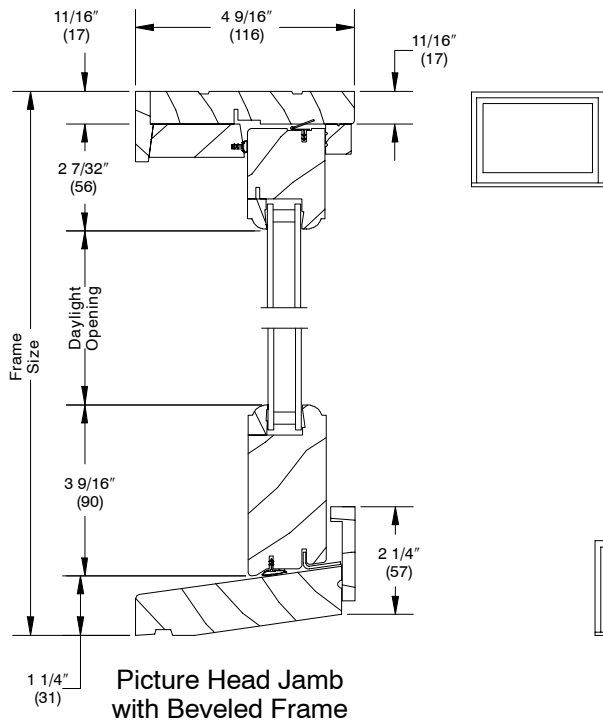

WOOD ULTIMATE INSERT DOUBLE HUNG

SECTION DETAILS: PICTURE

SCALE: 3" = 1' 0"

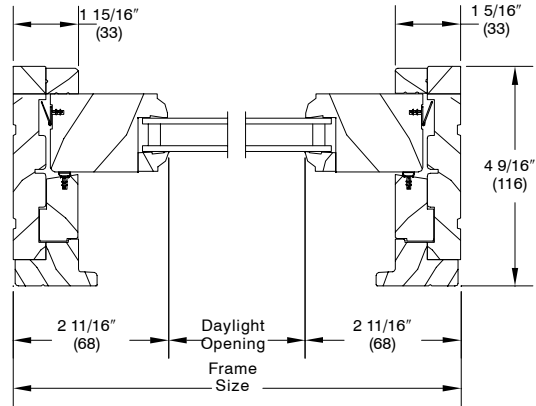

Picture Jamb

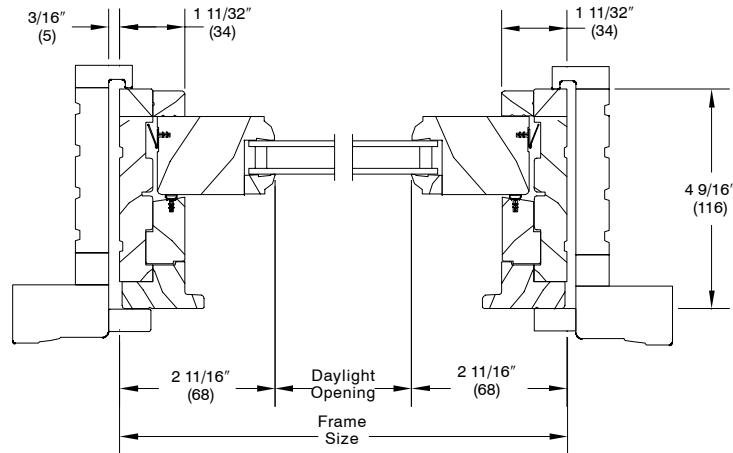

Picture Jamb installed in existing frame

WOOD ULTIMATE INSERT DOUBLE HUNG

SECTION DETAILS: MULLIONS

NOT TO SCALE

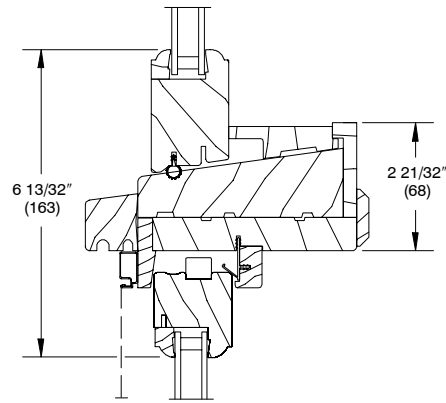

TRANSOM/OPERATOR
WINDH Horizontal Mullion

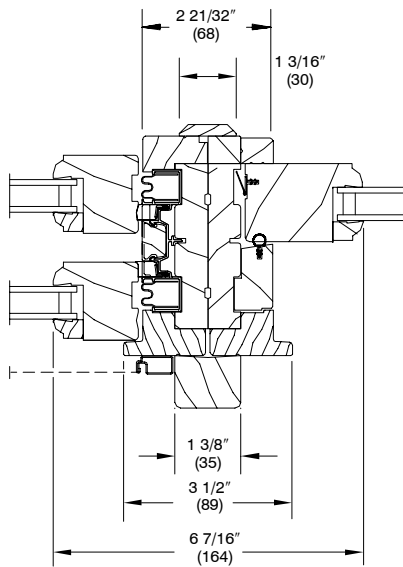

OPERATOR/PICTURE
WINDH Vertical Mullion

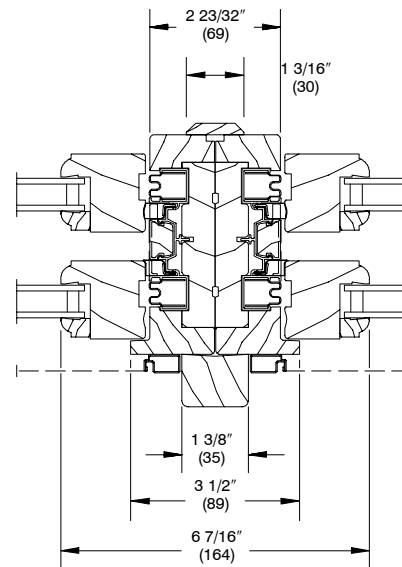

OPERATOR/OPERATOR
WINDH Vertical Mullion

NOTE:

Factory mulling options available for multiple assemblies up to inside opening sizes of 72" x 72". Contact your Marvin representative for additional information or special requests.

WOOD ULTIMATE INSERT DOUBLE HUNG

SECTION DETAILS: DIVIDED LITE OPTIONS

NOT TO SCALE

Operator and Transom

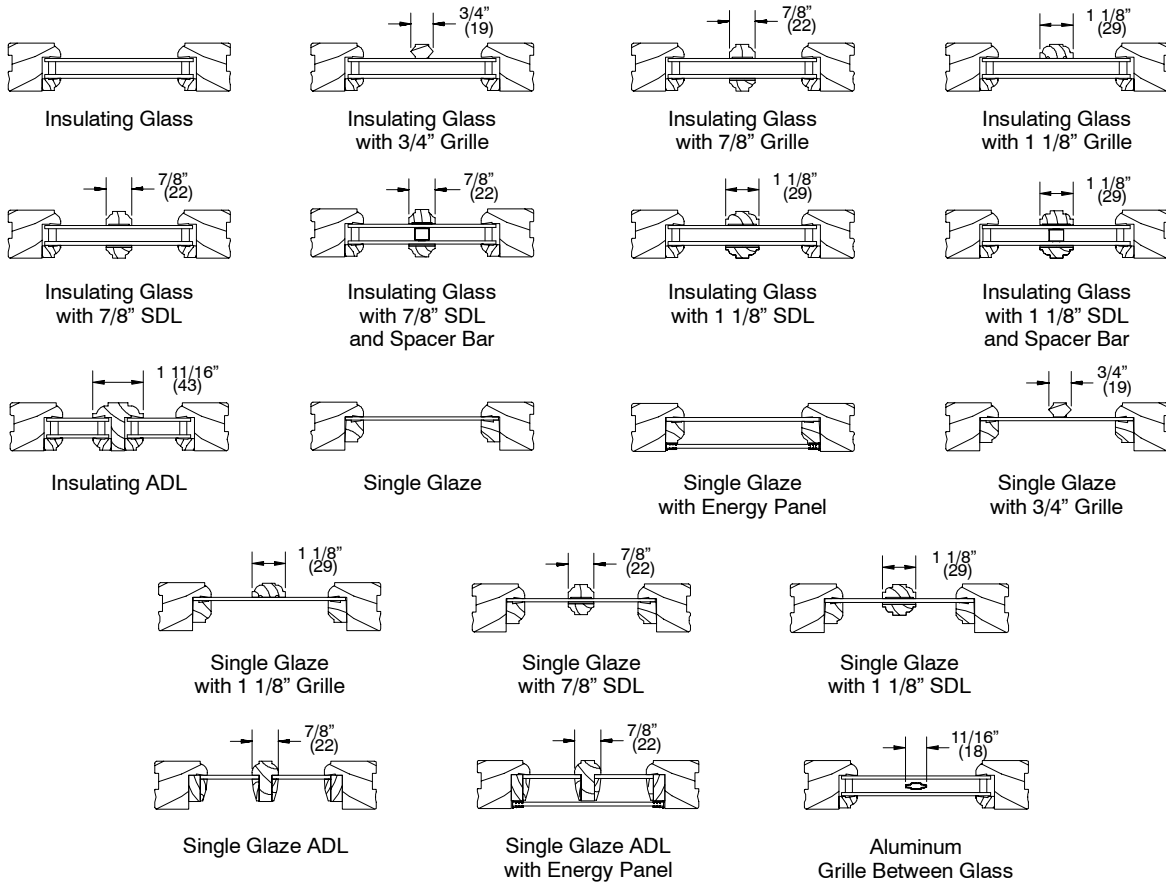

Picture Sash

NOTE:

Picture sash available in 1-5/8" and 2" sash thickness (2" picture sash not available in ADL).

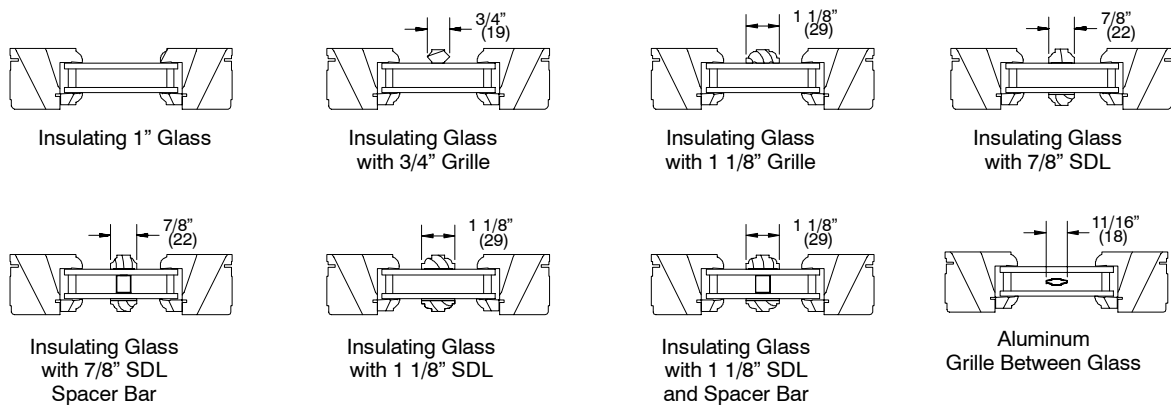

NOTE:

Grille = Removable interior divider
SDL = Simulated divided lite

WOOD ULTIMATE INSERT DOUBLE HUNG

DAYLIGHT OPENING CONVERSIONS

NOT TO SCALE

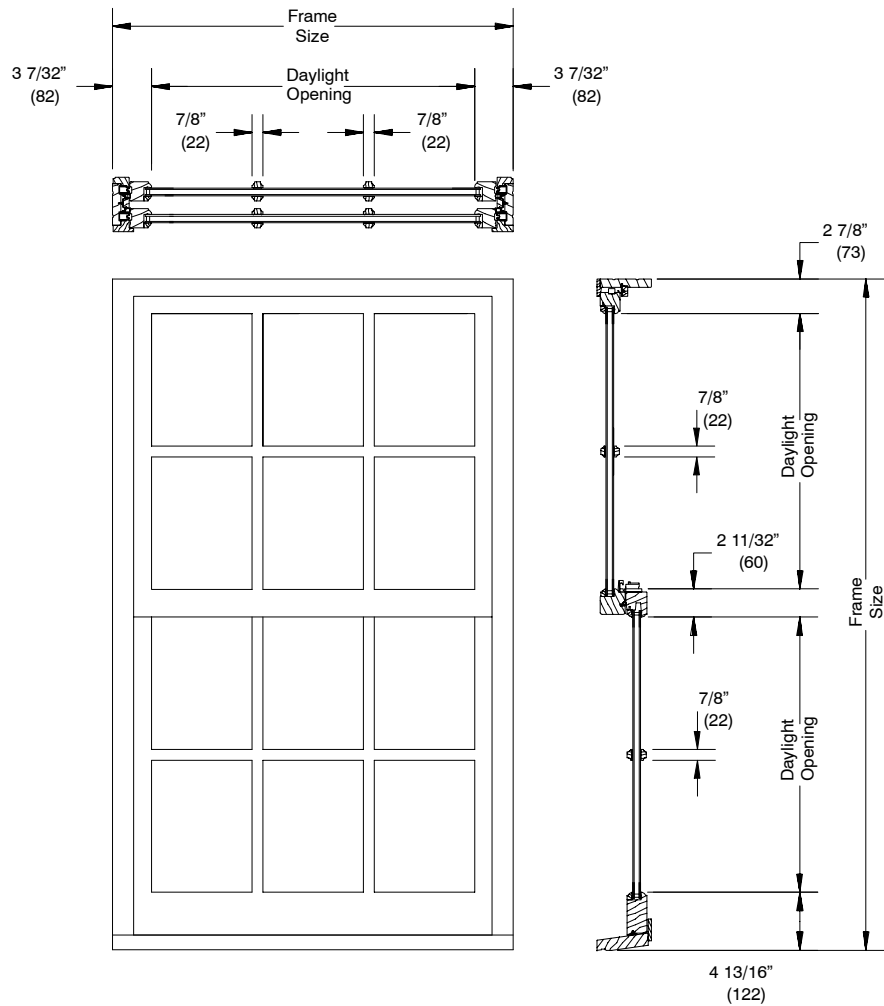

NOTE:

For additional information on individual daylight openings please contact your Marvin representative.

WOOD ULTIMATE INSERT DOUBLE HUNG

TRIM KIT
NOT TO SCALE

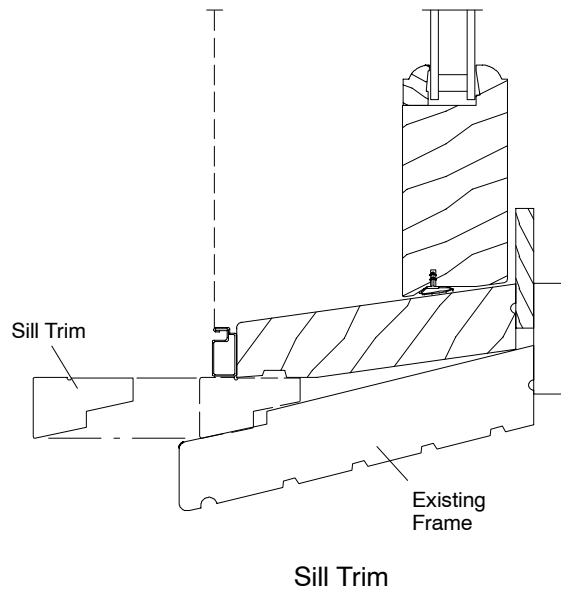
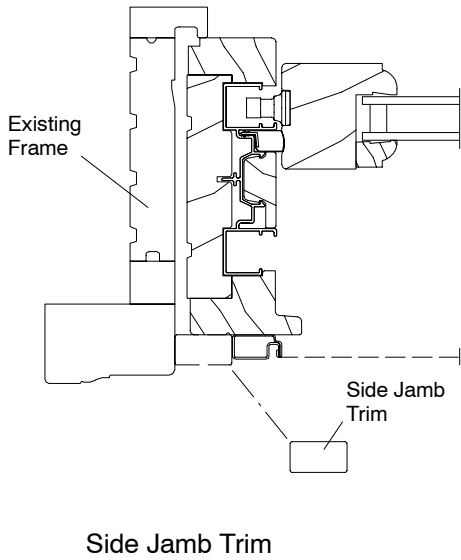
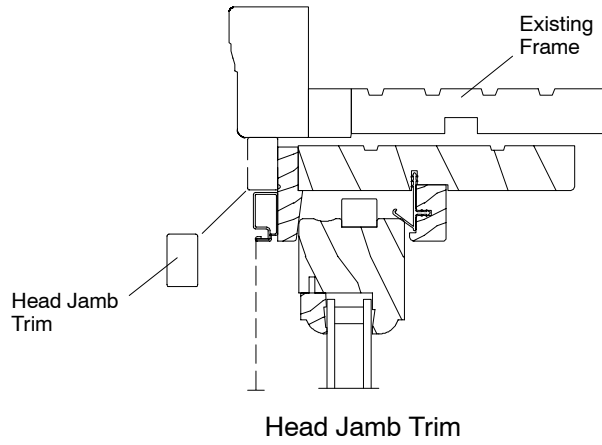

Exterior Side and Top Trim
(W8602)

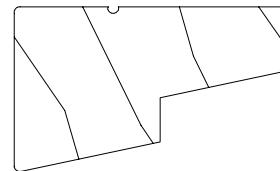

Exterior Sill Trim
(W8599)